



Sonata User Manual

IMPORTANT:

Do not use the SONATA PATIENT LIFTING HOIST without having first read this manual.

CONTENTS

SONATA 150 Overview	3
Important safety considerations	4
SONATA 150 Assembly instructions	6
Hoist operation and charging	7
Lifting procedures	10
Maintenance	12
Trouble shooting	13
Specifications	14
Warranty	15
Slings	16
Key to symbols	17
Parts list	17
Log Book	18

Overview

The **SONATA 150** is designed primarily for domestic use or a lightweight compact patient lifting hoist

The **SONATA 150** whilst being compact provides superior patient space through the use of SPACE LINK™ technology. The **SONATA 150** in fact offers more patient space than most other larger size lifters. The unique feature of SPACE LINK™ allows a patient to be rotated through 360° at full lift height, thus making the carer's job easier and safer.

The **SONATA 150** lifting range allows patients to be lifted from the floor, bed or chair with ease and safety.

The **SONATA 150** is a powered unit using trusted industry leading LINAK components, giving a safe working load (SWL) of 150kg

Options available with the **SONATA**

- ✓ Standard padded spreader bar
- ✓ Pivot frame
- ✓ Tri hook yoke
- ✓ Four point yoke
- ✓ Weighing device¹

The range of patient lifting equipment, including lifters, slings and accessories, has been designed and tested to comply with AS ISO 10535 – 2011, (Hoists for the transfer of disabled persons – Requirements and test methods)

¹  CAUTION - Weigh scale is not intended for clinical assessment.

IMPORTANT SAFETY CONSIDERATIONS

INTENDED USE OF THE PRODUCT

The **SONATA 150** compact mobile patient lifting hoist has been designed to lift and transfer a less able person with the assistance of a carer.

The **SONATA 150** should be used with one of the range of patient slings, as assessed by a competent trained person.

*NB. Not all slings and accessories are compatible with this hoist. If you are unsure please contact **HealthCo Ltd**.*

The correct and appropriate use of the **SONATA 150** hoist will reduce the risks associated with manual patient handling. The lifting / transferring task should be assessed & planned by a trained user.

SAFETY CONSIDERATIONS

- ✓ Ensure that all users read this guide before operating the hoist.
- ✓ Do not operate the hoist without training in the safe operation of hoists & slings. **IF IN DOUBT DO NOT USE.**
- ✓ Only use slings which have been assessed as suitable by a competent trained professional.
- ✓ Read the relevant sling users guide which is provided with each sling, before use.
- ✓ Do not use the hoist if there is any doubt about wear or damage to the unit. In particular the spreader bar or the Pivot Frame.
- ✓ Do not use the hoist if there is any fraying or stitch damage to the sling or if the sling is damaged in any other way.
- ✓ **DO NOT EXCEED THE SAFE WORKING LOAD OF THE SONATA 150 HOIST – 150kg**
- ✓ Ensure when the hoist is in use that the surrounding area is clear and the person being lifted is clear of all obstructing objects.



Direction of Travel



w: healthcoltd.co.uk

t: 01709 278036 | e: enquiries@healthcoltd.co.uk

The Croft House, York Lane, Rotherham, South Yorkshire, S66 9JH

ASSEMBLY INSTRUCTIONS

SONATA 150

The range of patient lifting and transfer hoists are fully assembled, load tested and certified at the factory before being partially dismantled for packing and shipping.

Use the instructions below as a guide to assemble your **SONATA 150** hoist.

1. Remove lifter components from protective packing and lay out on a smooth surface to prevent damage to powder coating on lifter sub assemblies.
2. Lift the mast assembly and slide into mast holder receiving socket on base chassis. Ensure the mast assembly is completely engaged in the mast socket. Tighten the locking clamp hex bolt to prevent movement between mast and base chassis.
3. Attach lift actuator to jib, by aligning actuator clevis with actuator mount bracket. Insert bolt and tighten nylock nut.
4. Attach push handle assembly with hex bolts supplied with handle assembly.
5. Insert the leg adjusting handle into the socket of the leg adjustable pivot mounted on the base chassis. Ensure handle key is aligned with cut-outs on the pivot
6. Check the operation of the leg adjustment mechanism to ensure the adjuster handle engages the three detent positions with ease of movement
7. Attach battery by clipping battery pack on top of control box.
8. Plug the lift actuator cable into port 1 positioned on the underside of the control box, ensuring it is driven firmly home in the socket.
9. Plug the handset lead into the large socket on underside of control box. (See next diagram) ensure alignment of tongue on handset plug with groove in control box handset connection port. When aligned press home firmly. A smear of Vaseline on the o ring may assist if plug is tight.
10. Check operation of lifter via handset, ensuring that the **RED EMERGENCY STOP BUTTON ON THE CONTROL BOX IS RELEASED**. Turn the knob quarter turn clockwise to release.

HOIST OPERATION AND CHARGING

HANDSET

- ✓ The handset activates the lift actuator by the use of two low pressure buttons, protected by a strong plastic cover. These are symbolised by arrows (diagram). The arrows indicate the direction of travel to raise or lower the hoist jib. When either button is released the jib will remain in position.
- ✓ The **SONATA 150** hoist incorporates an actuator driven leg opening adjustment. Two buttons will be seen on the handset with arrows and symbolised legs indicating the direction of travel. This function allows an unrestricted range of leg adjustment.
- ✓ The handset is also fitted with a battery indicator light. This will flash when the batteries reach a maximum discharge of 18 volts. NB the light will only flash when the hoist is under load.
- ✓ The connection for the handset is located on the underside of the control box.



ACTUATOR

The **SONATA 150** mobile patient lifting hoist uses a LINAK single speed actuator with an emergency controlled lowering release handle. (Twist red collar located at top of actuator shaft clockwise). This allows the patient to be lowered in the event of a fault in the hoist or deep discharged batteries.

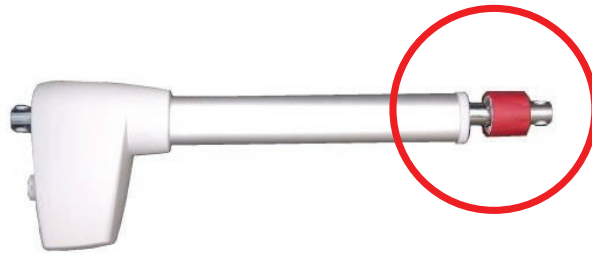

CHARGING

The **SONATA 150** is supplied with a integrated battery charger. This is powered by plugging the 3 pin plug into a standard 240V ac outlet when lifter is not in use. The charger may be plugged in at any time whilst not in use, to top up battery charging.

To recharge the battery pack, perform the following steps

- 1) Release battery pack from control box by pulling the handle on the pack towards you. Use both hands to support the battery pack when removing nor replacing it.
- 2) Clip the battery pack from the control box onto the charging unit, ensuring it is seated properly on the charger base
- 3) Charger will automatically activate the charging sequence

CHARGING INDICATOR DISPLAY

- ✓ GREEN mains power on light will be illuminated when connected to 240 v power supply.
- ✓ ORANGE LIGHT illuminated indicates battery currently charging.
- ✓ ORANGE LIGHT will extinguish when battery pack is fully charged.

SONATA 150 Internal Charging Unit

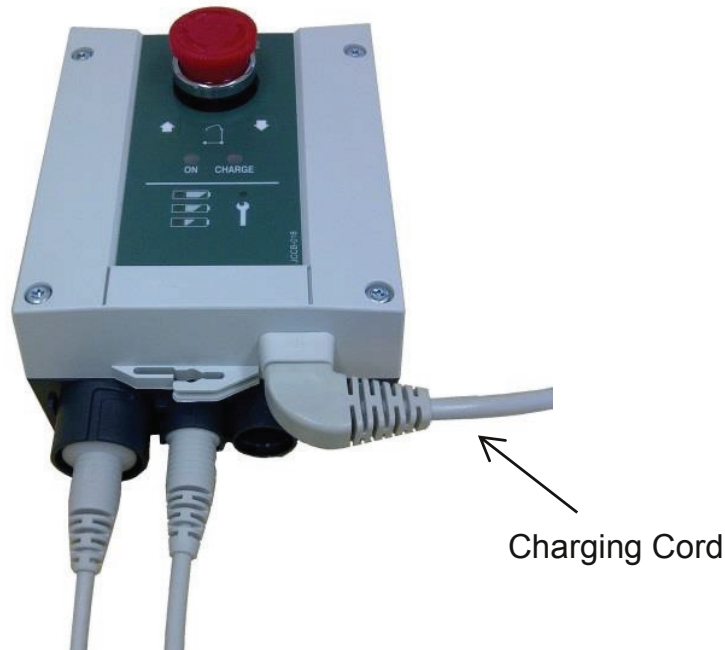

CHARGING DOs & DON'Ts

DO

Do charge the battery whenever possible. This will extend the battery life. A large number of cycles can be obtained from operating on the batteries, but battery lifetime is reduced with frequent discharging.

- ✓ Do inspect all cables particularly the mains power cable on the charger for any damage; replace where necessary.
- ✓ Do stow the handset and if fitted with charger, the mains power cable when transporting the hoist.
- ✓ Do clean the actuators, control box, charger, battery and handset at regular intervals to remove dust and dirt.

DON'T

- ✓ Don't allow the batteries to fully discharge before connecting to charger. The batteries are a lead acid gel type that can be trickle charged continuously and have a high current discharge capacity. The batteries are not the nickel cadmium type and must not be periodically fully discharged. Battery life is greatly reduced by deep or complete discharging of the batteries. Longer lifetime is obtained by maintaining fully charged batteries.

LIFTING PROCEDURES

- ✓ Carer should be fully conversant and trained in the use of lifter and sling. This will decrease patient apprehension and increase their co-operation and overall safety of the lifting process.
- ✓ Where possible always pull the lifter for maximum safety and comfort.
- ✓ Move the hoist slowly to avoid patient swing whilst standing.
- ✓ The hoist should not be used on uneven surfaces or on an incline greater than 5 deg.
- ✓ Never leave a patient in a sling unattended.
- ✓ Ensure brakes of the chair, bed, trolley that the patient is being lifted from are locked.
- ✓ The braking castors on the lifter should be off. This allows the lifter to create its own centre of gravity (C.G.) over the weight of the patient. N,B. This action may result in the lifter moving slightly during the initial phase of the lift.

GENERAL LIFTING PROCEDURE

The information supplied below is not intended to be construed as a training manual but as a general guide to lifting procedure only.

- ✓ Fit sling to patient (REFER TO SLING INSTRUCTION FOR USE).
- ✓ Manoeuvre the hoist around the patient, adjusting the legs to fit around chair, wheel chair etc. If lifting from a bed ensure under bed clearance is sufficient to manoeuvre the lifter legs.
- ✓ Lower the spreader bar sufficiently to allow fitting of sling attachment loops onto the spreader bar hooks. Ensure spreader bar does not contact with patients face or body.
- ✓ If using the Pivot Frame, lower the Pivot Frame sufficiently to allow attachment of the keyhole buckles onto the Pivot Frame studs.
- ✓ Use the handset to raise the hoist boom enough to take up the patients weight. At this point stop the lift, check all sling attachments are secure and that the sling is positioned correctly. Check patient comfort. Lower and realign sling if necessary.
- ✓ Continue to lift until patient is clear of chair, bed etc. ensuring that during the course of the lift the patient is clear of any obstructions.

MOVING THE PATIENT

A PATIENT HOIST IS PRIMARILY A LIFTING DEVICE. If possible always move patients from room to room in a wheelchair or other transport device. However, If you must move a patient while supported in a lifter the following are suggested:

- ✓ Lower the patient so the feet are just off the ground. This enhances the patients' perception of security.
- ✓ Where possible always pull the lifter rather than push, in particular when changing direction or steering around corners.
- ✓ Walk the rear of the hoist around so that it is heading in the new direction.
- ✓ Whilst manoeuvring in a small or confined area, two carers will make the job easier.
- ✓ Move the hoist smoothly and avoid abrupt stops and turns to minimise patient swing.

LOWERING THE PATIENT

- ✓ Position the patient over the chair or bed to be lowered onto and begin the lowering procedure with the handset down button. Check to make sure the patient remains comfortable during descent.
- ✓ All General Purpose and Pivot slings have handles sewn onto the back of the sling. These will assist the carer to pull back the patient into the correct position for seating.

GENERAL MAINTENANCE

To prolong the working life of the lifter and for trouble free operation it is recommended that periodic inspections should be performed routinely and as often as necessary. Periodic inspections should be performed by a person who is suitably qualified and well acquainted with the design, use and care of patient lifting hoists.

If inspection reveals that the safety of the hoist is jeopardised in any way the hoist should be *IMMEDIATELY WITHDRAWN FROM SERVICE*, tagged as such and the owner notified.

MAINTENANCE GUIDE & CHECK LIST

- ✓ General visual inspection of lifter.
- ✓ Check castors are tightly attached to legs.
- ✓ Check castors run & swivel freely, remove any hair & fluff from axle.
- ✓ Check castor brakes operate efficiently.
- ✓ Over haul castors & pack with grease.
- ✓ Inspect surfaces for scratches & chips
- ✓ Clean surfacers with a neutral detergent; remove any adhesive tape with orange or eucalyptus oil.
- ✓ Examine all moving parts and fasteners for wear and fatigue, lubricate and /or adjust as required.
- ✓ NB leg pivot bushes incorporate a Teflon coated pivot bush which requires minimal lubrication.
- ✓ Check tightness of bolt in leg bushes.
- ✓ Check linkages are secure in leg adjuster ball joints.
- ✓ Check all electrical components for correct operation.
- ✓ Check battery charger operation.
- ✓ Remove dirt & dust from actuator.
- ✓ Wipe actuator shaft with oiled rag (DO NOT use WD40 or equivalent.)
- ✓ Check SPACE LINK pivot link and regrease.
- ✓ Check spreader bar/tilt frame attachment to SPACE LINK. Remove bolt & regrease. Ensure SPACE LINK and attachments move freely.
- ✓ Check mast to boom pivot point, remove bolts and lightly regrease bush and retighten, ensuring free movement at pivot.

A MAJOR SERVICE SHOULD BE CARRIED OUT EVERY 12 MONTHS AS A MINIMUM REQUIREMENT.

IMPORTANT: An annual load test to the safe working load (swl) is required for compliance with AS ISO 10535 – 2011

TROUBLE SHOOTING

WARNING TROUBLE SHOOTING SHOULD ONLY BE CARRIED OUT BY HEALTHCO LTD AUTHORISED PERSONNEL FAMILIAR WITH BOTH USE, ELECTRICAL AND MECHANICAL FEATURES OF PATIENT LIFTING HOISTS.

The following is a guideline only to general trouble shooting.

Before carrying out any trouble shooting ensure that.

- ✓ Red emergency stop button is released.
- ✓ Maintenance procedures checked & followed.
- ✓ All cable connections are secure.
- ✓ Battery is fully charged.

	POSSIBLE FAULT	ACTION
Warning buzzer sounds within control box	Flat battery pack. Faulty battery pack.	Recharge battery. Replace battery.
Battery charger power indicator LED does not light up.	No mains connection. Internal fuse blown. Battery chargers is defective.	Plug into mains. Replace fuse. Repair/replace charger.
Actuator will not run and no relay click is heard from control box.	Control box is defective. Handset defective	Replace control box.
Actuator will not run via handset but control box relays click.	Actuator plug not pushed in to control box, Actuator defective. Control box defective.	Push firmly into correct port. Replace actuator or control.
Actuator cannot lift full load or runs slow.	Batteries not charged / defective. Load too high for lifter. Actuator motor damaged.	Charge/replace batteries. Replace actuator.
No response from control box, no clicking of relays is heard.	Emergency stop button engaged. Hoist battery completely flat. Blown fuse in battery pack. Faulty control box.	Release emergency stop button. Charge battery. Replace/repair control box.
Actuator works in one direction only	Handset defective. Control box defective.	Replace handset. Repair/replace control box.

SONATA 150 SPECIFICATIONS

Safe working load (SWL)	150kg	
Base length	1005mm	
External base width	605mm	
Internal base width closed	530mm	
Internal base width open	1010mm	
Maximum internal length	860mm	
Base width adjustment	3 Position Manually	
Under bed clearance	125mm	
Minimum height of spreader bar	340mm	
Maximum height of spreader bar	1685mm	
Hoisting range	930mm	
Height of centre suspension point @ max reach	134mm	
Lifter weight	39kg	
Minimum storage height	1235mm	
Patient lift space	165	
Under base height	50mm	
Maximum hoist reach	875mm	
Minimum hoist reach	445mm	
Maximum hoist reach @ maximum height	610mm	
Minimum hoist reach @ minimum height	435mm	
Turning radius	1100mm	
Weight of heaviest part (Base assembly)	17.5kg	
Handle height	1000mm	
Electrical approval	EN 60601-1	
Sound level	< 40Db @ 1m	
Electrical approval	EN 60601-1	
Operation force -	Finger	< 4N
	Hand	< 50N
	Foot	< 50N

WARRANTY

HealthCo Ltd warrants its products to be free from defects in materials and workmanship under normal use and service and will within the period stated below, from the date of purchase, repair or replace without cost to the original customer, any part assembly or portion thereof which shall be returned to **HealthCo Ltd** and from OUR inspection shows to be defective.

- ✓ Patient lifter including electronics - 2 years
- ✓ Accessories on lifter - 2 years
- ✓ Patient slings - 1 year
- ✓ Weighing devices¹ - 1 year
- ✓ Batteries - 3 months

HealthCo Ltd cannot be held responsible for any personal injury, damage to the hoist or damage to property as a result of the improper or unsafe use of the product.

No warranty claim shall apply where the product or any part thereof has been modified, varied, altered or damaged either accidentally or through improper or negligent use

No warranty claim shall apply where the hoist is repaired or serviced by any persons not accredited by the authorised distributor.

Warranty does not extend to items or components which may require replacement due to normal wear and tear (e.g. castors, mouldings and paint work) for which **HealthCo Ltd** nor its distributors can be held responsible.

BATTERIES

Batteries carry a limited warranty from the original manufacturer which is subject to a stringent wear and tear clause. Any battery faults due to defect in original manufacture will normally become apparent within the first two months of use.

Any gradual deterioration in performance after this period is normally associated with fair wear and tear, misuse and accidental damage, and as such is not covered by the manufacturers' warranty.

SLINGS

HealthCo Ltd manufactures a large range of patient lifting slings in both mesh and fabric to suit the range of patient lifting hoists. A range of custom made to specification slings are available on request.

SLING SIZES AVAILABLE

• XSmall, • Small, • Medium, • Large, • XLarge, • XXLarge

MAIN SLING CATEGORIES

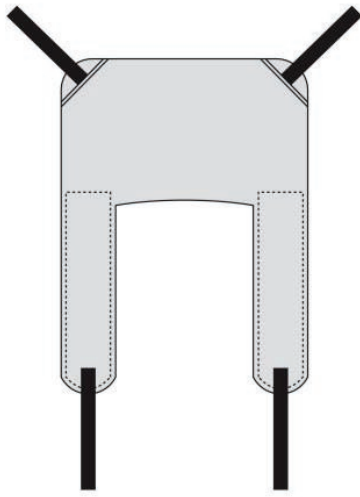

General Purpose Sling

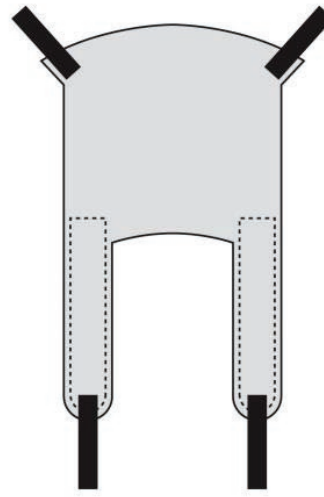

General Purpose Sling with Head Support

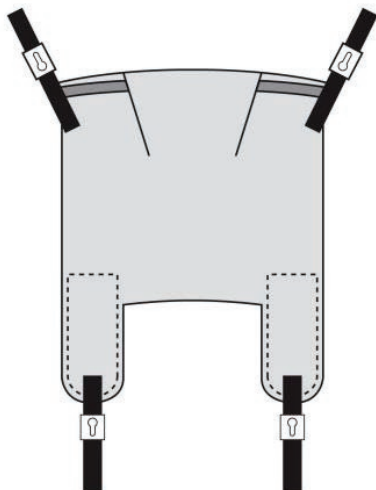

Pivot Sling

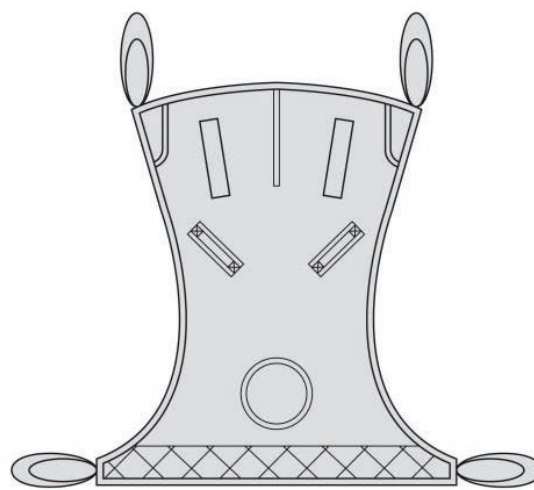

Amputee Sling

KEY TO SYMBOLS

The following symbols are used on the lifter and attachments including the range of General Purpose and Pivot slings.

SWL Safe working load: this symbol represents the maximum load the lifter, sling or attachment is rated to for safe operation.

SLING CARE SYMBOLS



Do not use bleach.



Wash at a max temp of 85° Celsius.



Do not iron.



Do not dry clean.



Do not tumble dry.

SLING MAINTENANCE AND CARE

WARNING: Prior to use, inspect slings including webbing, straps and key hole buckles for wear. Examine stitching for fraying, breakage and unravelling.

DAMAGED SLINGS SHOULD NOT BE USED.

PARTS LIST AND DESCRIPTION

A full parts list is available upon request

LOG BOOK

Service Type	Condition Report
Date:	
Inspected by:	
Signature:	
Action taken:	Date:

Service Type	Condition Report
Date:	
Inspected by:	
Signature:	
Action taken:	Date:

Service Type	Condition Report
Date:	
Inspected by:	
Signature:	
Action taken:	Date:

Service Type	Condition Report
Date:	
Inspected by:	
Signature:	
Action taken:	Date: